



INTERNATIONAL APPLICATION PUBLISHED UNDER THE PATENT COOPERATION TREATY (PCT)

<p>(51) International Patent Classification <sup>6</sup> : <b>H04Q 3/00</b></p>	<p><b>A1</b></p>	<p>(11) International Publication Number: <b>WO 95/20297</b></p>
		<p>(43) International Publication Date: 27 July 1995 (27.07.95)</p>
<p>(21) International Application Number: PCT/GB95/00087 (22) International Filing Date: 18 January 1995 (18.01.95) (30) Priority Data: 94300379.8 19 January 1994 (19.01.94) EP (34) Countries for which the regional or international application was filed: GB et al. (71) Applicant: BRITISH TELECOMMUNICATIONS PUBLIC LIMITED COMPANY [GB/GB]; 81 Newgate Street, London EC1A 7AJ (GB). (72) Inventor: ALLISON, David, Stephen; 10 St. Ellens, Edenderry, Belfast BT8 8JN (GB). (74) Agent: EVERSLED, Michael; BT Group Legal Services, Intellectual Property Dept., 13th floor, 151 Gower Street, London WC1E 6BA (GB).</p>		<p>(81) Designated States: CA, CN, JP, KR, NZ, European patent (AT, BE, CH, DE, DK, ES, FR, GB, GR, IE, IT, LU, MC, NL, PT, SE).  Published With international search report.</p>

(54) Title: AN ELEMENT MANAGER FOR A COMMUNICATIONS NETWORK

(57) Abstract

An element manager for a telecommunications network comprises a data store and first and second interfaces for connecting the data store, respectively, to a network manager and to the individual network elements managed by the element manager. The data store comprises a network of cells. Each cell is connected to at least one other cell by an individual communication channel and each communication channel permits two cells to send messages directly to each other. The network of cells includes a sub-network of cells arranged in the form of a management information tree. The sub-network includes a cell (60) which represents the root of the management information tree, a cell (61) which represents the network and cells (62 to 68) which represent elements of the network. The cells are connected by communication channels (68).

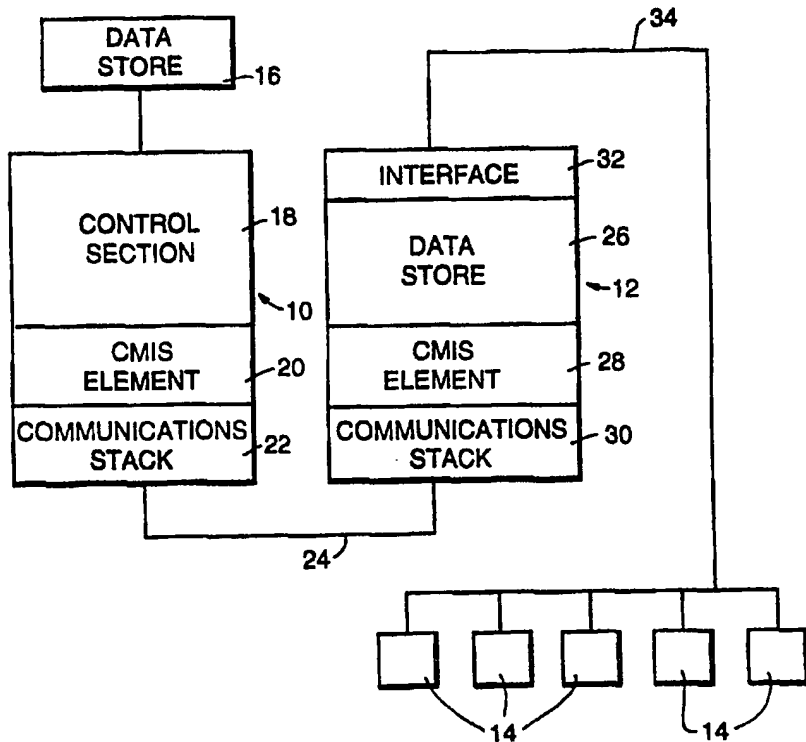

**FOR THE PURPOSES OF INFORMATION ONLY**

Codes used to identify States party to the PCT on the front pages of pamphlets publishing international applications under the PCT.

AT	Austria	GB	United Kingdom	MR	Mauritania
AU	Australia	GE	Georgia	MW	Malawi
BB	Barbados	GN	Guinea	NE	Niger
BE	Belgium	GR	Greece	NL	Netherlands
BF	Burkina Faso	HU	Hungary	NO	Norway
BG	Bulgaria	IE	Ireland	NZ	New Zealand
BJ	Benin	IT	Italy	PL	Poland
BR	Brazil	JP	Japan	PT	Portugal
BY	Belarus	KE	Kenya	RO	Romania
CA	Canada	KG	Kyrgystan	RU	Russian Federation
CF	Central African Republic	KP	Democratic People's Republic of Korea	SD	Sudan
CG	Congo	KR	Republic of Korea	SE	Sweden
CH	Switzerland	KZ	Kazakhstan	SI	Slovenia
CI	Côte d'Ivoire	LI	Liechtenstein	SK	Slovakia
CM	Cameroon	LK	Sri Lanka	SN	Senegal
CN	China	LU	Luxembourg	TD	Chad
CS	Czechoslovakia	LV	Latvia	TG	Togo
CZ	Czech Republic	MC	Monaco	TJ	Tajikistan
DE	Germany	MD	Republic of Moldova	TT	Trinidad and Tobago
DK	Denmark	MG	Madagascar	UA	Ukraine
ES	Spain	ML	Mali	US	United States of America
FI	Finland	MN	Mongolia	UZ	Uzbekistan
FR	France			VN	Viet Nam
GA	Gabon				

AN ELEMENT MANAGER FOR A COMMUNICATIONS NETWORK

This invention relates to an element manager for managing individual network elements of a communications  
5 network.

A modern network management system for a communications network comprises a network manager and a number of element managers connected to the network manager and each of which manages a large number of individual  
10 network elements. A network management system provides various management functions including fault management, event management and configuration management. Each element manager includes a data store which holds data on the individual network elements managed by it. Presently, there  
15 is no satisfactory way of representing the relationships between the various network elements in the data store of the element manager.

According to one aspect of this invention, there is provided an element manager for managing individual network  
20 elements of a communications network, said element manager comprising a data store containing data on the individual network elements, a first interface for connecting the data store to a network manager, and a second interface for connecting the data store to the individual network elements,  
25 said data store comprising a network of cells some of which represent respective individual network elements, each cells being connected to at least one other cell by an individual communication channel, each communication channel permitting two cells to send messages to each other.

30 In the element manager of this invention, the cells which represent individual network elements together with the communication channels represent the relationships between the network elements.

Preferably, each cell has a function part which  
35 controls the function of the cell and a data part which contains data.

Conveniently, said network of cells includes a sub-network of cells which collectively hold information for managing individual network elements, said sub-network comprising a group of cells arranged in a hierarchical structure and each of which represents a respective one of the network elements and another cell which contains a mapping between the individual network elements and identifiers for the cells which represent the network elements.

10 The principles used in the data store of the element manager may be applied to other types of data store which contain data on individual physical objects.

According to a second aspect of this invention, there is provided a data store for containing data on individual physical objects, said data store comprising a network of cells some of which represent respective physical objects, each cell being connected to at least one other cell by an individual communication channel, each communication channel permitting two cells to send messages to each other directly.

20 This invention will now be described in more detail, by way of example, with reference to the drawings in which:

Figure 1 is a block diagram of a network management system for a telecommunications network which includes an element manager embodying this invention;

25 Figure 2 is a diagram of a software cell used in a data store forming part of the element manager;

Figure 3 shows the relationship between a software cell representing a network element and a set of other cells which contain data relating to the attributes of the network element;

30 Figure 4 shows the relationship between software cells representing various network elements;

Figure 5 is a diagram of a sub-network of software cells which perform a control function within the data store;

35 Figure 6 is a diagram of a sub-network of software cells which are responsible for creating cells which represent network elements; and

- 3 -

Figure 7 is a diagram of a sub-network of software cells for performing a filtering operating on cells which represent network elements.

Referring now to Figure 1, there is shown a block diagram of a network management system for a telecommunications network which comprises a network manager 10 and an element manager 12 for managing individual network elements 14. The element manager 12 is connected to the network manager 10. Although not shown in Figure 1, a network manager 10 would normally be connected to several element managers. For reasons of simplicity, Figure 1 shows only five network elements 14 managed by the element manager 12. In practice, an element manager will manage a very large number, perhaps tens of thousands, of individual network elements. Examples of network elements which can be managed by an element manager include a telephone exchange and its various component parts and a multiplexer and its ports.

The network manager 10 is implemented as a computer, the main software components of which are shown in Figure 1. The software components include a data store 16, a control section 18, a CMIS element 20, and a communications stack 22. The data store 16 contains data on the network elements managed by the element manager 12. The control section 18 is responsible for retrieving data from, and writing data into, the data store 16, and for generating commands to and receiving responses from the element manager 12. The commands and responses are generated by using a standardised service known as the Common Management Information Service (CMIS). The CMIS element 20 translates the commands and responses into, and out of, data units of a standardised protocol known as the Common Management Information Protocol (CMIP). CMIS and CMIP are defined respectively in the following two standards, namely, ISO/IEC/9595 and ISO/IEC/9596. The communications stack 22 is responsible for converting the CMIP data units into a form suitable for transmission along a serial data link 24. The serial link 24 is established between the network manager 10 and the element

manager 12 when it is desired to transmit data between them. The communication stack 22 is available from Retix Inc of Santa Monica, California, USA. The general construction of a network manager is known to those skilled in the art.

5           The element manager 12 is also implemented as a computer, the main software components of which are shown in Figure 1. These components include a data store 26 which contains data on the network elements 14, a CMIS element 28 similar to the CMIS element 20, a communications stack 30  
10 similar to the communications stack 22 and an interface 32 for converting instructions generated in the data store 26 into a form suitable for transmission along a serial data link 34 to the network elements 14 and also for converting  
15 data received from the network elements 14 along the data link 34 into a form suitable for transmission to the data store 26. It will be observed that the CMIS element 28 and the communications stack 30 together form an interface between the data store 26 and the data link 24. The general construction of an element manager is known to those skilled  
20 in the art. The data store 26 embodies this invention and will be described in further detail below.

It is known to provide an element manager for network elements which does not have an interface for communication with a network manager. If desired, the data store 26, CMIS  
25 element 28 and the communication stack 30 may be combined with such an element manager by providing a suitable interface between the data store 26 and the element manager.

The data store 16 of the network manager 10 stores the data on the individual network elements by using a technique  
30 known as object-oriented programming. In this technique, a software module or object contains an image of the function and attributes of a physical object such as a network element or an abstract object.

The main services provided in CMIS are achieved by  
35 issuing the following commands: a create command, a delete command, a get command, a set command, an action command and an event-report command. These commands will be explained

- 5 -

with reference to the network management system of Figure 1. A create command is a command issued by the network manager 10 to instruct the element manager 12 to create a software object. A delete command is a command issued by the network manager 10 to instruct the element manager 12 to delete a software object. A get command is issued by the network manager 10 to the element manager 12 to obtain values of the attributes of a particular software object. The set command is issued by the network manager 10 to the element manager 12 in order to set the values of the attributes of a particular object to specified values. An event-report is issued by the element manager 12 to the network manager 10 in order to inform the network manager 10 of some event which has occurred in a particular physical object managed by the element manager 12.

CMIS also permits the network manager 10 to perform what is known as a filtering operation on the data in data store 26. In a filtering operation, the values of certain attributes of certain software objects are tested to determine if they match specified values.

The software in the data store 26 is divided into cells. Each cell has the same basic construction and the construction of an exemplary cell 40 is shown in Figure 2. The cell 40 has two parts, namely, a function part 42 and a data part 44. The function part 42 specifies the functions which are performed by the cell. The data part 44 contains a set of variables. Each cell also has a unique identifier.

Each cell is connected to a number of other cells by respective communication channels. Each communication channel is unique to two cells and permits the two cells to send messages to each other directly. Each message has the following fields:

<u>Field</u>	<u>Description</u>
5 Communication Channel	Sending: identifier for the communication channel on which the message is to be sent  Receiving: identifier of the communication channel on which message was received
10 Cell	Sending: no use  Receiving: identifier of cell which sent the message
15 Message Identity Reference	Identifier for the message  A reference to identify this particular message.
20 Data	The data which is to be passed with the message.

Each cell contains a list of the identifiers for the communication channels to which it is connected and the identifier for the cell connected to the other end of each communication channel.

To send a message to another cell along a communication channel, the sending cell must specify the communication channel along which the message will be sent, the message identifier, a reference for the message and the data of the message. The reference permits the receiving cell to correlate messages of the same type arriving on a particular communication channel.

When a message is received, the receiving cell will be in an operational state and will act on the message accordingly. From the knowledge of the identifier for the communication channel on which the message was received and the list of communication channel identifiers and the corresponding cell identifiers, the receiving cell will be able to determine the identifier of the cell which sent the message.

The specification for each cell, which is included in the function part of the cell, specifies the types of message which it can receive. If a cell attempts to send a message



- 7 -

to another cell and the receiving cell is not prepared to accept it because it is not one of the types of message which it can accept, the message will not be sent and an error code will be returned by the sending cell to the receiving cell.

5       The data store 26 has a support system for the cells. The support system is responsible for carrying message along the communication channels and it is able to both create and destroy communication channels.

10       The communication channels form the individual cells into a network of cells. The network of cells itself is divided into four sub-networks. These comprise a first sub-network of cells which collectively contain the information which is necessary for managing the network elements, a second sub-network of cells which is responsible for  
15       controlling the other cells, a third sub-network of cells which is responsible for creating the cells of the first sub-network, and a fourth sub-network of cells which is responsible for performing the filter function described above. The sub-network of cells which creates the cells of  
20       the first sub-network is also responsible for creating the cells of the fourth sub-network. These sub-networks will now be described in turn.

As mentioned above, the first sub-network contains the data which is necessary for managing the network elements.  
25       The first sub-network views the network elements as a collection of managed objects. Some of these managed objects correspond exactly to network elements but other managed objects correspond either to a set of network elements or an abstract concept. For this reason, the first sub-network  
30       will be described in terms of managed objects rather than network elements.

The first sub-network contains a group of cells each of which represents one of the managed objects. Each of these cells is connected to a set of further cells by  
35       communication channels, these further cells containing the values of the attributes of the managed object. By way of modification, the values of the attributes of each managed

object may be stored in the data part of the corresponding managed object cell. With this modification, attribute cells are not provided.

The managed object cells are arranged in a hierarchical structure to form what is known as a management information tree. One of the managed object cells represents what is known as the root of the management information tree. Apart from the managed object cell which represents the root of the management information tree, each managed object cell is connected by a communication channel to the managed object cell which represents the managed object (the parent managed object) which is immediately superior to the managed object which it represents itself. Apart from the managed object cells which represent the extremity of the managed information tree, each managed object cell is also connected by a set of communication channels to corresponding set of managed object cells which represent managed objects (child managed objects) which are immediately inferior to the managed object represented by the cell itself.

Referring to Figure 3, there is shown an example of a managed object cell 50 which is connected by a set of communication channels 51 to four cells 52 which contain the values of the attributes of the managed object represented by the managed object cell 50. The cell 50 is also connected by a communication channel 53 to the managed object cell which represents the parent managed object of the managed object represented by cell 50. Figure 3 also shows a set of communication channels 54 for connecting the cell 50 to three managed object cells which themselves represent managed objects which are immediately inferior to the managed object represented by 50.

Referring now to Figure 4, there is shown a set of managed object cells arranged as a greatly simplified management information tree. In Figure 4, the attribute cells are omitted. The managed object cell of Figure 4 comprise a cell 60 which represents the root of the management information tree, a cell 61 which represents the

telecommunications network, cells 62, 63 and 64 which respectively represent a circuit, a switch and a multiplexer in the network, and cells 65, 66 and 67 which represent three of the ports of the multiplexer represented by cell 64. The  
5 child-parent relationship is evident from Figure 4. For example, the network represented by cell 61 is a parent managed object to the multiplexer represented by cell 64. The communication channels between the individual cells are indicated by reference numerals 68.

10 The data held in the data part of each managed object cell includes the name of the managed object represented by the cell, the identifier for the communication channel which connects the cell to its parent cell, a list of the  
15 identifiers for the communication channels which connect the cell to its child cells, and a list of identifiers for the communication channels which connect the cell to its attribute cells together with a list of the attributes whose values are stored in the attribute cells.

20 The first sub-network also includes a cell which has a directory of the identifiers of all the managed object cells and the names of the managed object which they represent.

Referring now to Figure 5, there is shown the second sub-network, which is responsible for controlling the other  
25 sub-networks, together with its relationship to the CMIS element 28 and the interface 32. This sub-network has first and second main cells 70, 72, a first group of bridge cells 74 and a second group of bridge cells 76. The first main cell 70 is responsible for receiving messages from, and  
30 sending messages to, the CMIS element 28. The second main cell 72 is responsible for receiving messages from, and sending messages to, the interface 32.

Each of the bridge cells 74 is responsible for transmitting messages between the two main cells 70 and 72.  
35 These messages represent commands or confirmation of commands and a further function of the bridge cells 74 is to check for confirmation of a command. Thus, if the main cell 70

- 10 -

transmits a message via one of the bridge cells 74 to the main cell 72 relating to a command for a particular network element to perform a specified function, the bridge cell 74 will check for confirmation that the command has been carried  
5 out.

The bridge cells 76 are responsible for transmitting messages between the main cell 70 and the cells of the other sub-networks. These messages relate to the various CMIS services. Consequently, the bridge cells 76 are divided into  
10 five types which are responsible, respectively, for handling create commands, delete demands, get commands, set commands and event-report operations. Each of the bridge cells 76 is connected to the main cell 70, the directory cell of the first sub-network which is indicated in Figure 5 by reference  
15 numeral 78, and the main cell of the third sub-network which is indicated in Figure 5 by reference numeral 80.

The bridge cells 74 are created when required and then destroyed after they have performed their function.

In Figure 5, the communication channels are indicated  
20 by reference numeral 82.

Referring now to Figure 6, there are shown some cells of the third sub-network. This sub-network comprises the main cell 80 mentioned above and a large interconnected network of managed object cells and their associated  
25 attribute cells. For reasons of simplicity, Figure 6 shows only three managed object cells, namely, cells 92, 94, and 96. The attribute cells are indicated by reference numeral 98 and the communication channels are indicated by reference numeral 100. The structure of the cells in this sub-network  
30 represents the general structure of the various type of managed object cells and their relationships to their attribute cells. The variables in the attribute cells are set initially to default values.

When the main cell 80 receives a command to create a  
35 new managed object cell, it instructs one of the managed object cells in this sub-network, for example one of cells 92, 94 or 96, to reproduce itself together with its

- 11 -

associated attribute cells. The managed object cell which reproduces itself passes a message to the main cell 80 indicating the possible parent and child managed object cells for the newly created managed object and this message is then  
5 passed back to the main cell 70 of the second sub-network. The second sub-network is then responsible for connecting the newly created managed object cell at its correct position in relation to the existing managed object cells.

The fourth sub-network performs the filter operation  
10 defined by CMIS. This sub-network is divided up into a number of individual filters. Each filter contains a set of cells for performing logical functions and a set of cells for testing the values of the attributes held in attribute cells. The logical functions are AND, OR, and NOT. Thus the  
15 functions cells are divided into AND-cells, OR-cells and NOT-cells. The test cells can test if the value of an attribute held in an attribute cell is equal, less than or greater than a specified value. Filters are created by the third network under the control of its main cell 80.

20 An example of a filter is shown in Figure 7. This filter has an AND-cell 110, an OR-cell 112 and a NOT-cell 114, and three test cells 116, 118 and 120. The cells 110, 112, 114, 116, 118 and 120 are connected together by communication channels 128 so as to perform the required  
25 filter operation. The test cells 116, 118 and 120 are connected to attribute cells 122, 124 and 126 by communication channels 130. The AND-cell 110 is connected via a communication channel 132 to a bridge cell, not shown, in the second sub-network.

30 There will now be described a selection of scenarios which serve to demonstrate the operation of the data store  
26.

In the first scenario, a new managed object cell is created. This operation commences when the main cell 70 of  
35 the second sub-network receives a message from the CMIS element 28 instructing it to create a new managed object cell. The message specifies the type of managed object cell

- 12 -

and the value of the attributes of the object to be represented by the cell. The main cell 70 then builds a bridge cell of the type which can perform the operation of creating a new managed object cell. At this stage, the main  
5 cell 70 is connected to the bridge cell. The bridge cell is then connected to the directory cell 78 and also to the main cell 80 of the third sub-network. The bridge cell is also connected to the managed object cell which represents the root of the management information tree in which the new  
10 object is located.

The third sub-network creates the new managed object cell together with its associated attribute cells and the new managed object cell is connected to the bridge cell. The bridge cell then transmits the values of the attributes to  
15 the new managed object cell which passes the values on to its attribute cells where the values of the attributes are set to the value specified.

The main cell 70 then sends a message to the directory cell 78 via the bridge cell to obtain the identifier for the  
20 cell which will be the parent of the new managed object cell. The bridge cell is then connected to the parent cell and the message is then sent to the parent cell to instruct it to adopt the newly created managed object cell.

The parent cell then connects itself to the new  
25 managed object cell and the bridge cell together with its associated communication channels is destroyed.

In the second scenario, a managed object cell is destroyed.

This operation commences when the main cell 70 of the  
30 second sub-network receives a message from the CMIS element instructing it to destroy a particular managed object cell. The main cell 70 then creates a bridge cell which is capable of performing the function of destroying a cell. The bridge cell then connects itself to the directory cell 78 to obtain  
35 the identifier for the cell which is to be destroyed. Using this identifier, the bridge cell then connects itself to the managed object cell which to be destroyed and sends it a

- 13 -

message to instruct it to destroy itself. On receiving this message, the managed object cell checks if it has any child cells and, if so, instructs them to destroy themselves. The managed object cell then destroys itself and a confirmation  
5 message is sent via the bridge cell to the main cell 70. The bridge cell then destroys itself.

In the third scenario, the value of an attribute of a particular managed object cell is obtained. This scenario commences when the main cell 70 receives a request asking it  
10 to obtain the attribute value. It then creates a bridge cell for performing the operation of getting the value of the attribute. The bridge cell then connects itself to the directory cell 78 and obtains the identifier for the particular managed object cell. The bridge cell connects  
15 itself to the managed object cell and asks it to read the value of the attribute concerned. The managed object cell reads the value of the attribute and sends this via the bridge cell to the main cell 70. The bridge cell then destroys itself.

20 In the fourth scenario, an attribute of a particular managed cell is set to a specified value. This scenario commences when the main cell 70 receives a command instructing it to set the attribute to the specified value. It then builds a bridge cell for performing the operation of  
25 setting an attribute to a specified value. The bridge cell then connects itself to the directory cell 78 and obtains the identifier of the particular managed object. Using this identifier, the bridge cell connects itself to the managed object cell and sends it an instruction to set the attribute  
30 to the specified value. When it has done this, the managed object cell sends a confirmation message via the bridge cell to the main cell 70. The bridge cell then destroys itself.

The first to fourth scenarios described above correspond, respectively, to the create, delete, get and set  
35 services defined by CMIS.

There will now be described a scenario in which the value of a particular attribute of a real managed object, for

- 14 -

example the bandwidth of a circuit, is changed. This scenario commences when the control section 18 of the network controller 10 sends a command to the CMIS element 20 to instruct the attribute to be set to the specified value.

5 This command is transmitted to the main cell 70 which then forms a bridge cell for connecting itself to the main cell 72. The message is then passed via the bridge cell to the main cell 72 which, in turn, passes the message to the real managed object.

10 The real managed object then sets its attribute to the specified value and returns a confirmation message to the main cell 72. This message is transmitted via the bridge cell to the main cell 70. Following the procedure described in the fourth scenario, the main cell 70 then sets the value  
.15 of the attribute of the corresponding managed object cell to the specified value. The main cell 70 then sends a confirmation message back to the control section 18 of the network controller 10.

If the real managed object is unable to sets its  
20 attribute to the specified value, it sets it to the nearest possible value and includes this value in its confirmation message. In these circumstances, the main cell 70 sets the value of the attribute of the managed object cell to the value which has been achieved by the real managed object and  
25 returns this value in its confirmation message to the control section 18.



- 15 -

CLAIMS

1. An element manager for managing individual network elements of a communications network, said element manager  
5 comprising a data store containing data on the individual network elements, a first interface for connecting the data store to a network manager, and a second interface for connecting the data store to the individual network elements, said data store comprising a network of cells some of which  
10 represent respective individual network elements, each cell being connected to at least one other cell by an individual communication channel, each communication channel permitting two cells to send messages to each other directly.
- 15 2. An element manager as claimed in claim 1, in which each cell has a functional part which controls the function of the cell and a data part which contains data.
- 20 3. An element manager as claimed in claim 1 or claim 2, in which the data store includes a support system for the network of cells, said support system including means for creating communication channels and means for destroying communication channels.
- 25 4. An element manager as claimed in any one of the preceding claims, in which said network of cells includes a sub-network of cells which collectively hold information for managing individual network elements, said sub-network comprising a group of cells arranged in a hierarchical  
30 structure and each of which represents a respective one of the network elements and another cell which contains a mapping between the network elements and identifiers for the cells which represent the network elements.
- 35 5. An element manager as claimed in claim 4, in which each cell of said group of cells arranged in a hierarchical structure is connected by a respective communication channel

- 16 -

to at least one further cell which contains data on the attributes of the network element represented by the cell.

6. An element manager as claimed in claim 4 or claim 5, in which said network of cells includes a sub-network of cells for creating the cells which form said group of cells arranged in a hierarchical structure.

7. An element manager as claimed in any one of the preceding claims, in which said network of cells includes a sub-network of cells for controlling the network of cells, said control sub-network comprising a first main cell for receiving messages from and transmitting messages to said first interface, a second main cell for receiving messages from and transmitting messages to said second interface, at least one cell which acts as a bridge for passing messages between said first and second main cells, and a set of cells which act as bridges for passing messages between said first main cell and the cells of said network of cells which do not form part of the control sub-network.

8. A management system for a telecommunications network comprising a network manager, at least one element manager as claimed in any one of the preceding claims, the or each element manager being connected to the network manager, and a set of network elements connected to, and managed by, the or each element manager.

9. A data store for containing data on individual physical objects, said data store comprising a network of cells some of which represent respective individual objects, each cell being connected to at least one other cell by an individual communication channel, each communication channel permitting two cells to send messages to each other directly.

35

- 17 -

10. A data store as claimed in claim 9, in which each cell has a functional part which controls the function of the cell and a data part which contains data.
- 5 11. A data store as claimed in claim 9 or claim 10, including a support system for the network of cells, said support system including means for creating communication channels and means for destroying communication channels.

Fig.1.

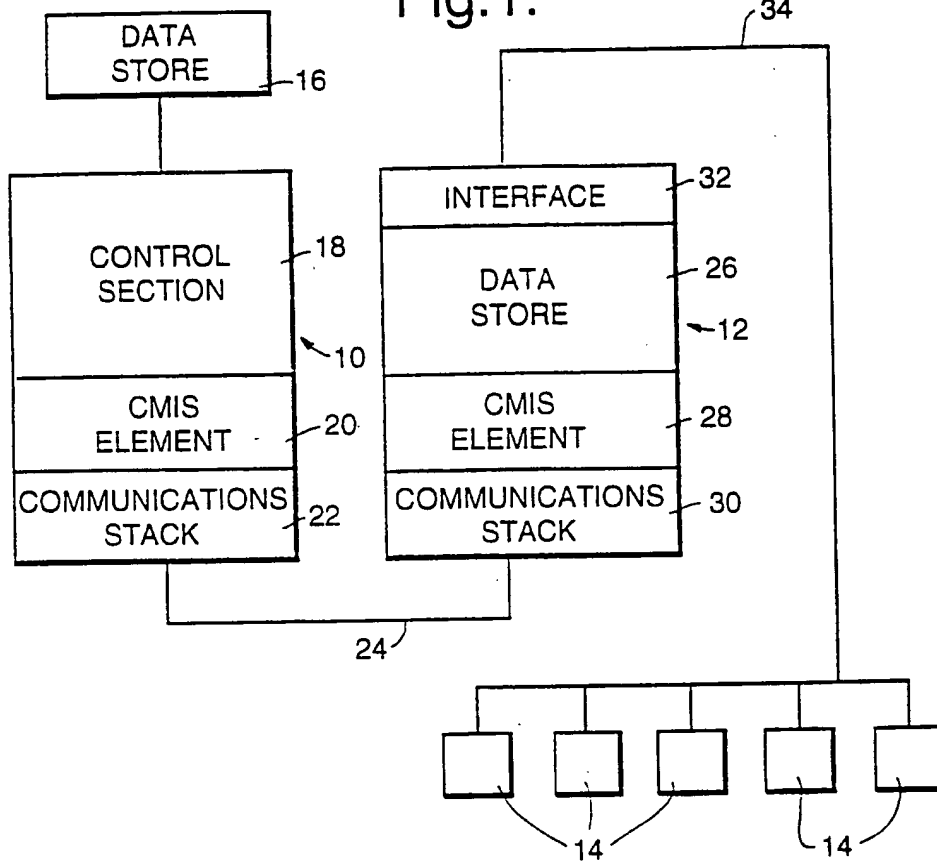
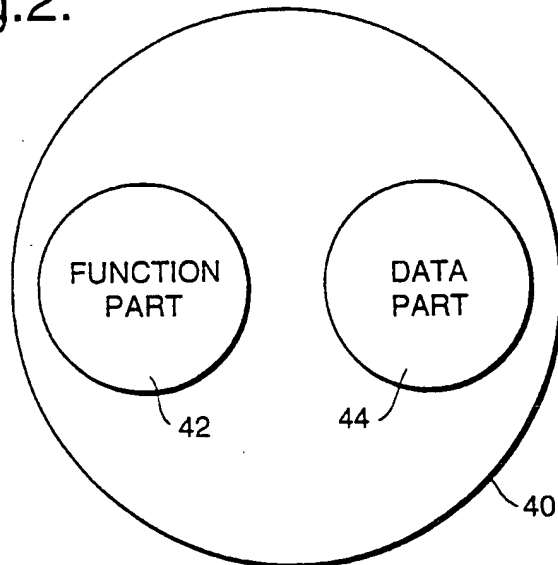
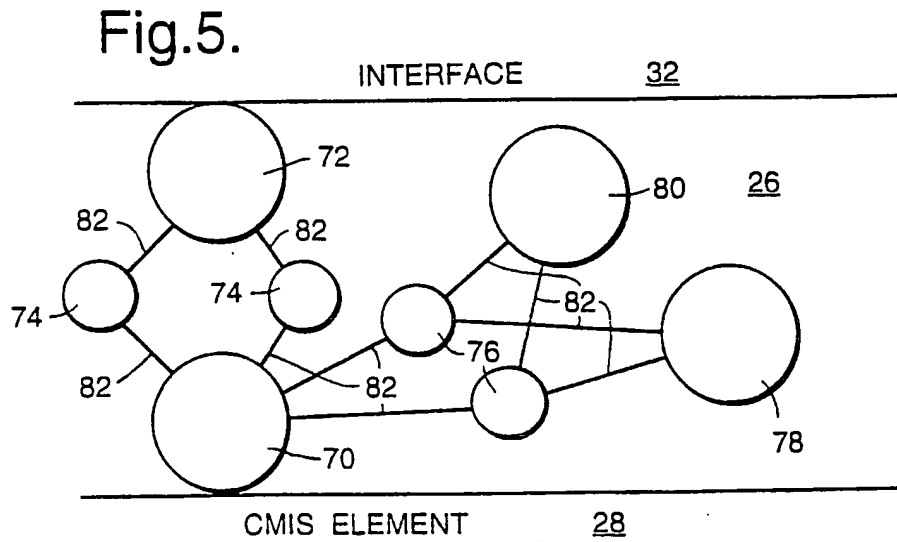
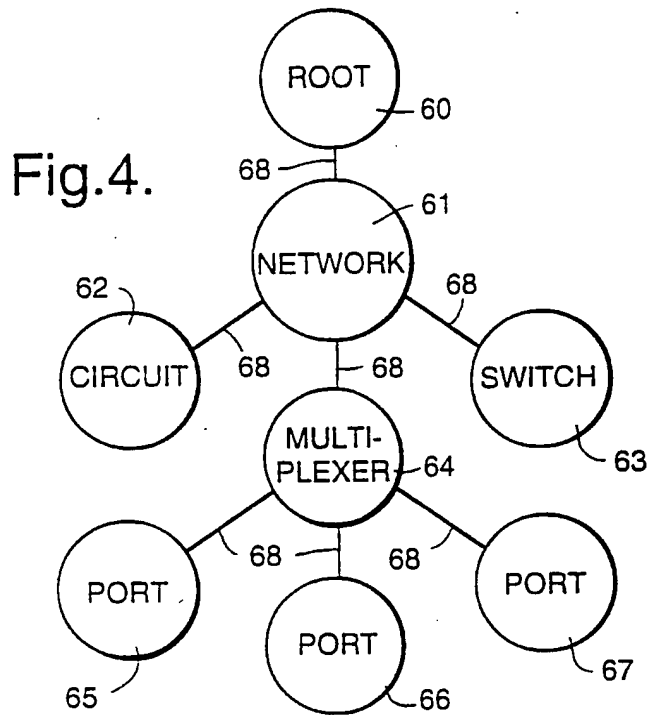
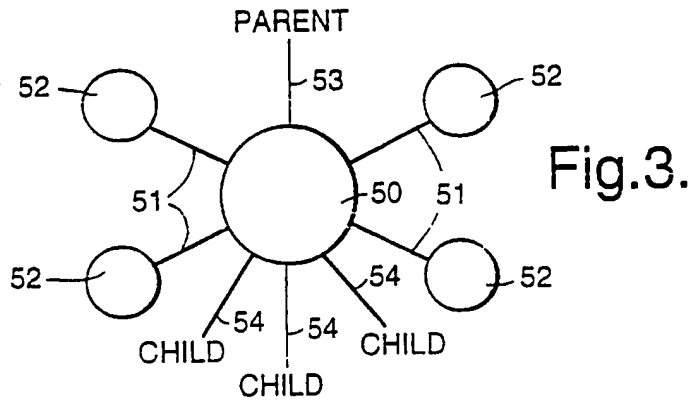
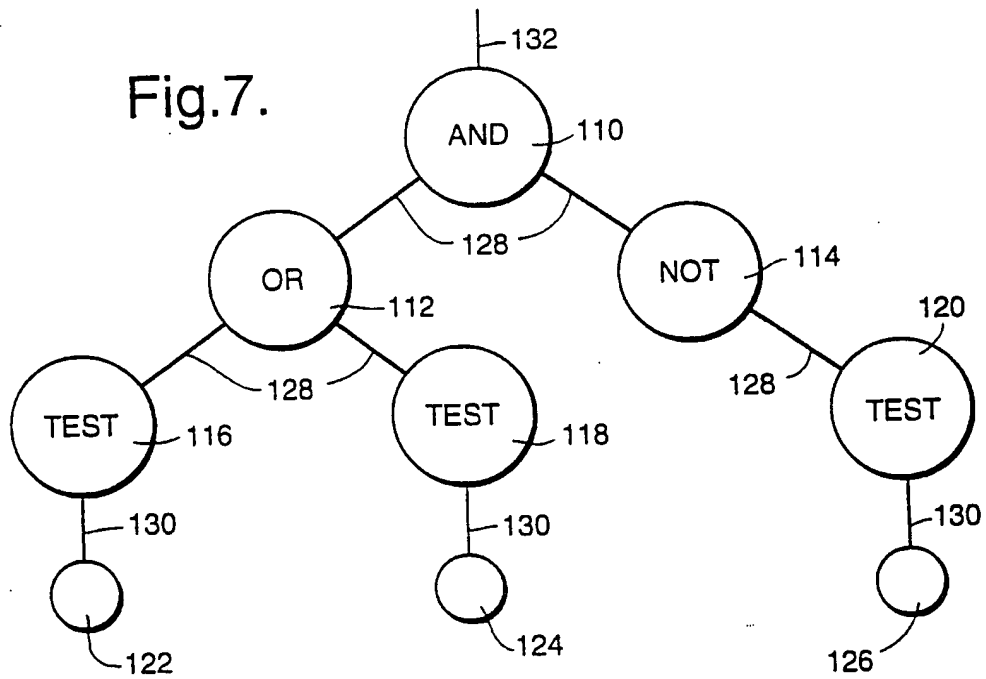
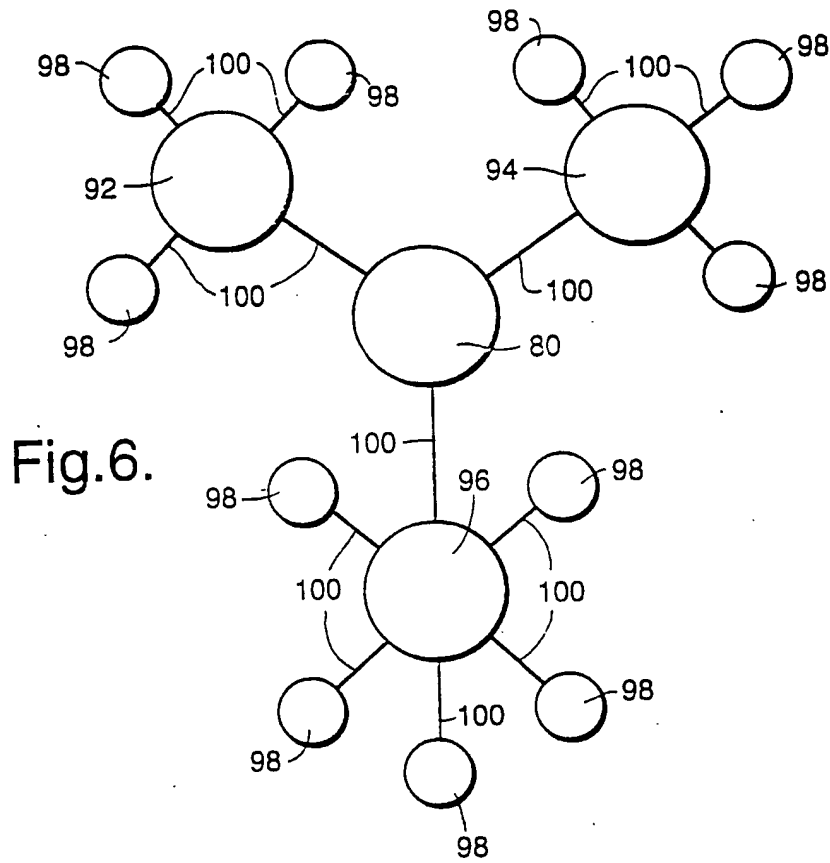

Fig.2.







INTERNATIONAL SEARCH REPORT

International Application No  
PCT/GB 95/00087

A. CLASSIFICATION OF SUBJECT MATTER  
IPC 6 H04Q3/00

According to International Patent Classification (IPC) or to both national classification and IPC

B. FIELDS SEARCHED

Minimum documentation searched (classification system followed by classification symbols)  
IPC 6 H04Q

Documentation searched other than minimum documentation to the extent that such documents are included in the fields searched

Electronic data base consulted during the international search (name of data base and, where practical, search terms used)

C. DOCUMENTS CONSIDERED TO BE RELEVANT

Category *	Citation of document, with indication, where appropriate, of the relevant passages	Relevant to claim No.
A	IEEE GLOBAL TELECOMMUNICATIONS CONFERENCE & EXHIBITION - GLOBECOM '90, SESSION 802, PAPER 6, vol. 3, SAN DIEGO US, page 1498 LIAO ET AL. 'Toward the Intelligent Integrated Network Management' see section III: 'IINM system model'; section V: 'Manager architecture'	1,4,8
A	WO,A,93 18598 (NOKIA TELECOMMUNICATIONS) 16 September 1993 see abstract; claim 1; figure 1 see page 7, line 31 - page 8, line 19 see page 11, line 25 - page 12, line 12 --- -/--	1,8

Further documents are listed in the continuation of box C.

Patent family members are listed in annex.

\* Special categories of cited documents :

- \*A\* document defining the general state of the art which is not considered to be of particular relevance
- \*E\* earlier document but published on or after the international filing date
- \*L\* document which may throw doubts on priority claim(s) or which is cited to establish the publication date of another citation or other special reason (as specified)
- \*O\* document referring to an oral disclosure, use, exhibition or other means
- \*P\* document published prior to the international filing date but later than the priority date claimed

- \*T\* later document published after the international filing date or priority date and not in conflict with the application but cited to understand the principle or theory underlying the invention
- \*X\* document of particular relevance; the claimed invention cannot be considered novel or cannot be considered to involve an inventive step when the document is taken alone
- \*Y\* document of particular relevance; the claimed invention cannot be considered to involve an inventive step when the document is combined with one or more other such documents, such combination being obvious to a person skilled in the art.
- \*&\* document member of the same patent family

Date of the actual completion of the international search

5 April 1995

Date of mailing of the international search report

26.04.95

Name and mailing address of the ISA  
European Patent Office, P.B. 5818 Patentlaan 2  
NL - 2280 HV Rijswijk  
Tel. (+31-70) 340-2040, Tx. 31 651 epo nl,  
Fax (+31-70) 340-3016

Authorized officer

Lambley, S

INTERNATIONAL SEARCH REPORT

International Application No  
PCT/GB 95/00087

C.(Continuation) DOCUMENTS CONSIDERED TO BE RELEVANT		
Category *	Citation of document, with indication, where appropriate, of the relevant passages	Relevant to claim No.
A	<p>IEEE GLOBAL TELECOMMUNICATIONS CONFERENCE - GLOBECOM '91, SESSION 19, PAPER 4, vol. 1, PHOENIX US, page 643 STEPIEN ET AL. 'Bell Canada's generic Network Element Control technology' see page 643, left column, paragraph 2 - right column, paragraph 6; figure 1 ---</p>	1
A	<p>ICL TECHNICAL JOURNAL, vol. 7, OXFORD GB, page 763 MAYNARD-SMITH 'The Network Management domain' see section 5.1: 'The Element Manager' -----</p>	1

1



# INTERNATIONAL SEARCH REPORT

Information on patent family members

International Application No

PCT/GB 95/00087

Patent document cited in search report	Publication date	Patent family member(s)	Publication date
WO-A-9318598	16-09-93	EP-A- 0630539	28-12-94

**This Page is Inserted by IFW Indexing and Scanning  
Operations and is not part of the Official Record**

**BEST AVAILABLE IMAGES**

Defective images within this document are accurate representations of the original documents submitted by the applicant.

Defects in the images include but are not limited to the items checked:

- BLACK BORDERS**
- IMAGE CUT OFF AT TOP, BOTTOM OR SIDES**
- FADED TEXT OR DRAWING**
- BLURRED OR ILLEGIBLE TEXT OR DRAWING**
- SKEWED/SLANTED IMAGES**
- COLOR OR BLACK AND WHITE PHOTOGRAPHS**
- GRAY SCALE DOCUMENTS**
- LINES OR MARKS ON ORIGINAL DOCUMENT**
- REFERENCE(S) OR EXHIBIT(S) SUBMITTED ARE POOR QUALITY**
- OTHER:** \_\_\_\_\_

**IMAGES ARE BEST AVAILABLE COPY.**

**As rescanning these documents will not correct the image problems checked, please do not report these problems to the IFW Image Problem Mailbox.**